

**SPECIFY GAIN AND PHASE MARGINS ON
ALL YOUR LOOPS**

H. Dean Venable • Venable Instruments

www.venableinstruments.com



VENABLE TECHNICAL PAPER # 2

Specify Gain And Phase Margins On All Your Loops

Abstract:

When purchasing a power supply, the knowledgeable buyer should specify the gain and phase margins of all feedback loops within a power supply. The commonly- specified main loop should be specified for stability margins not only as shipped with local sense, but with remote sense and extra output capacitance as well. Any separately regulated additional outputs should be specified too, and also the margins of the current limit loops if the supply has active current limiting.

Introduction

When purchasing a power supply, the focus is normally on the performance of the main output. This performance is usually based on ripple, noise, and output voltage deviation and recovery time when subjected to a transient load. Although these parameters are important, they do not tell the whole story. Many power supply buyers have procured equipment that seemed to work, only to find out later that the margins were insufficient to account for manufacturing tolerances, and that not all units worked properly when placed in the field. Specifying acceptable margins and testing for these margins in production can avoid many field failures and the attendant cost and customer dissatisfaction.

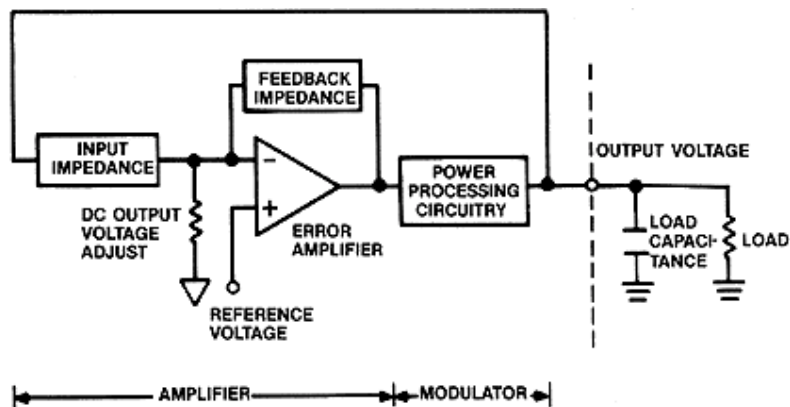

Figure 1. Block Diagram of Power Supply Feedback Loop

Stability Margins

Power supplies regulate output voltage by sensing the output and feeding a portion of it back to be compared to a constant voltage reference. The difference between the fraction of the actual output voltage and the reference is amplified, and the amplified difference signal is used to control the power-processing portion of the circuit to keep the output voltage constant. Figure 1 shows this process. The output of the power processing circuit, or MODULATOR, is compared to a reference in the AMPLIFIER portion, and the difference is amplified and inverted and fed to the control input of the modulator.

The process is the same for the current limit loop; if the supply has active current limiting that regulates the current rather than shutting down. In this case, a voltage proportional to current from a sense resistor or current transformer is compared to a reference voltage representing the maximum allowable current, and the difference is amplified and inverted and fed back to input of the modulator. Most pulse width modulator (PWM) chips have transconductance (high output impedance) error amplifiers so that the outputs of the voltage and current error amplifiers can be connected directly together. The amplifier output, which calls for the lowest duty cycle, dominates.

When the output of a circuit is connected back to the input, a potential for oscillation exists. When a signal proceeds around this feedback loop it is amplified or attenuated, and shifted in phase. At low frequency the signal is amplified. As the frequency increases, the loop gain drops, until a frequency is reached where the return signal is exactly the same amplitude as the input error signal. This is known as the unity gain frequency, crossover frequency, or bandwidth. If the phase shift around the loop at this frequency totals 360° (180° from phase shifts and time delays, plus 180° from the inversion), the circuit will oscillate.

Figure 2 shows a typical plot of loop gain and phase shift versus frequency. The gain is decreasing with frequency, and crosses unity gain (0 dB) at about 3 kHz. The phase lag at low frequency is mostly from the error amplifier. The total phase lag is about 270° , 180° from the inversion and another 90° from the pole at the origin in the amplifier gain. As the phase lag through the modulator portion becomes significant, the total phase shift lags more and more. When the loop gain is 0 dB, the difference between the total phase lag and 360° is the PHASE MARGIN. As the frequency increases, the point is reached where the total phase shift around the loop does total 360° and the gain has dropped below unity. The amount the gain is below 0 dB when the total phase shift is 360° is called GAIN MARGIN. Phase margin and gain margin are the stability margins of the particular feedback loop.

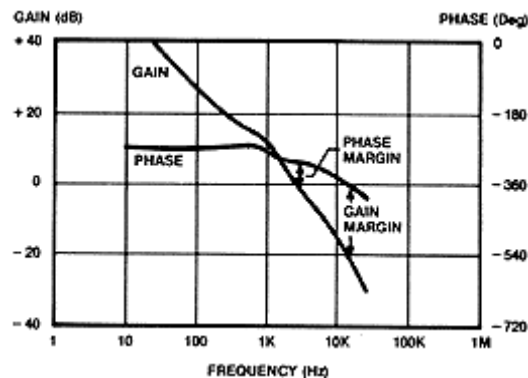

Figure 2. Typical Loop Bode Plot Showing Margins

How Much Margin Is Enough?

When specifying margins, one should take into account whether the testing will be done at nominal or worst case conditions. While a phase margin of one degree is theoretically enough, in practice a minimum (worst case) margin of 20 to 30° is a much safer value. Some new specifications are requiring phase margin of 30° and gain margin of 10 dB. The 30-degree phase margin specification is reasonable, but often difficult to achieve in the worst case. The 10 dB gain margin spec is not reasonable when coupled with 30° of phase margin. Phase and gain margins are related, and 30° of phase margin typically yields about 5 dB of gain margin. In order to meet the 10 dB gain margin specification a phase margin closer to 60° is required. Table 1 shows reasonable values of phase and gain margins. Servo designers frequently choose 45° as a design guideline for phase margin. This value yields a response, which is critically damped and has the best compromise of response and settling time. If changes in other system parameters will not degrade the phase margin significantly; 45° is a reasonable design choice.

In power electronic circuits, changes in line, load and temperature tend to degrade phase margin markedly from the nominal value. For commercial equipment, where the temperature variations are mild, a nominal phase margin of 60° is usually enough to accommodate manufacturing tolerances. If external factors such as use of remote sensing or variable amounts of filter capacitance can affect phase margin then more than 60° of nominal phase margin may be desirable. Military designs with their wide temperature swings should start with a higher nominal value, such as 75°, to try to maintain 20-30° of phase margin in the worst case. Dr. Middlebrook of Caltech recommends 72° of phase margin. This value yields all real roots in the closed-loop transfer function of a system, which means that there is no peaking in closed-loop transfer function at the open-loop crossover frequency. Peaking of the output impedance at the loop crossover frequency is also reduced. The penalty for this additional phase margin is reduced gain at low frequency (reducing the line-frequency ripple rejection) and slower transient response time. The optimum choice of phase margin and bandwidth is determined by the application. The important thing is to measure the bandwidth and margins rather than guess at them or ignore them.

Measuring Gain And Phase Margins

Gain and phase margins refer to open-loop gain. In most cases, it is not practical to open the loop, since the dc gain is very high and the loop will tend to drift to one extreme or the other when the loop is open. Fortunately, in most cases it is not necessary to open the loop to measure the open loop gain. By inserting a low-amplitude ac source in series with the feedback loop at a point where the source impedance (looking backward into the loop) is low and the input impedance (looking forward into the loop) is high, separate input and output voltages can be measured with respect to signal ground. The ratio of output to input voltage is loop gain. Sweeping the frequency of an inserted ac source and measuring both the amplitude and phase of the input and output voltages allows a plot of open-loop gain and phase to be obtained. Figure 3 shows a typical test set-up. In a power supply, there are normally two places, which meet the insertion criteria for impedance. One insertion point is between the output of the power supply and the top of the resistor string, which connects to the error amplifier input, as shown in Figure 3. The other valid insertion point is between the error amplifier and the modulator. A convenient method of inserting the ac voltage is to connect a low-value resistor, typically 100 ohms, in series with the feedback loop at one of the two valid insertion points. A transformer is then used to isolate an oscillator output so that the inserted signal can truly float with minimal capacitive loading. Then a

frequency response analyzer is used to measure the input and output voltages with respect to ground and calculate the ratio of the two voltages in both gain and phase.

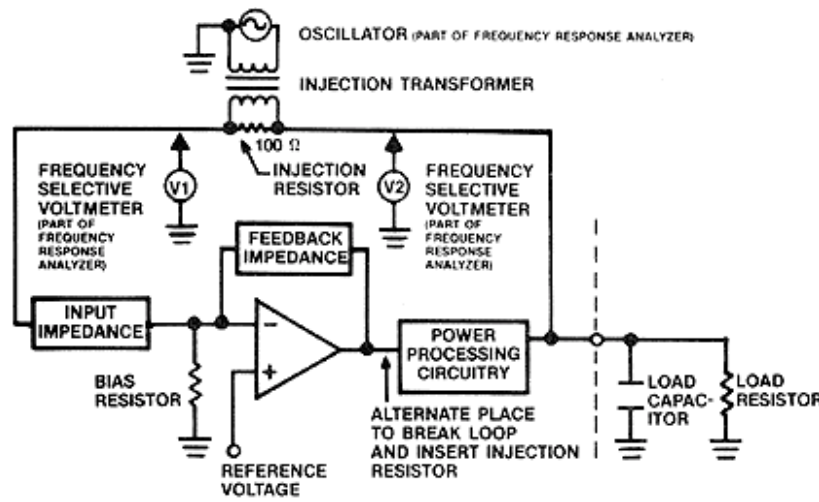

Figure 3. Technique for Making Bode Plot Measurements

Where Are The Loops?

Everyone knows about the main loop, which in a power supply is typically closed from the output with the heaviest load to the primary side regulator. There may be, and usually are, many other loops in a power supply, each of which has unique gain and phase margins. Common additional loops are on independently regulated outputs other than the main loop. In larger power systems, there is frequently an auxiliary or housekeeping supply, intended to provide internal voltages for the various control and monitoring circuits inside the power system.

A popular technique for regulating secondary outputs is by the use of power magamps, really saturable reactors which block a variable portion of the volt-seconds delivered by the power transformer to the output filter. By adjusting the blocking time, the average and thereby the dc value of the output can be controlled. The use of magamps or saturable reactors creates a time delay in the local feedback loop. The delay is because control information is stored in the saturable reactor in the form of a flux reset level, and this information is returned at a later time when the reactor saturates on the next half-cycle. This time delay translates to a phase lag in the feedback loop, which limits the achievable bandwidth of the control loop.

In some supplies, the current limit circuit is an active feedback loop. If the current limit is not a "bang-bang" or shutdown type, it has a loop, which must be stabilized. In addition, it should not interfere with the related voltage loop for the particular output being protected. The techniques for stabilizing a current feedback loop are exactly the same as for a voltage loop. The resistor values tend to be lower, necessitating a lower value of insertion resistor, but all principles remain the same, including gain and phase margin guidelines.

What Loop Crossover Frequency Is Reasonable?

Maximum achievable loop bandwidth (crossover frequency) is a function of many factors, but it is important to consider the effect of external influences. Power supply switching frequencies are steadily increasing, with some commercially- available supplies now switching at a rate in excess

of 1 MHz. Old loop bandwidth guidelines of 10-20 percent of the switching frequency no longer apply at the new higher frequencies. If remote sensing is to be used, a bandwidth of 1-3 kHz for the loop is the maximum realistic range. Higher bandwidths will cause oscillation when the remote sense feature is used, due to additional phase shift through the external circuit (lead inductance and load capacitance) independent of internal topology or operating frequency.

If local sense is used, some of the higher- frequency supplies can achieve bandwidths of up to 20 kHz unless the customer adds additional filter capacitance to the output. Additional filter capacitance can dramatically reduce loop bandwidth, since the internal filter capacitor in many new designs is only a few microfarads. It is not unusual for the customer to parallel those few microfarads with a few thousand microfarads externally, reducing the output filter corner frequency, loop gain, and crossover frequency.

Why Step Load Testing is Not Adequate

Step load testing has been commonly used for years as a means of confirming stability. Although easy to implement, it suffers from three serious drawbacks.

The most serious problem with step load testing is that it does not reveal conditional stability. Figure 4 shows a conditionally stable loop. With conditional stability, the phase shift reaches and even exceeds a total of 360° while there is still gain in the loop. A loop can only oscillate at the frequency where the loop gain is unity (0 dB). As proved by Nyquist [1] and discussed by Tuttle [2], if the total phase shift is reduced to an amount less than 360° at the unity gain frequency, even though it exceeded 360° at a lower frequency and higher gain, the loop is still stable. In fact, the transient response of such a loop is excellent, since the loop gain increases rapidly below crossover. The problem is that if something should cause the loop gain to decrease, such as a low line or heavy load condition, the loop may oscillate and destroy itself before it ever reaches the stable operating point. A Bode plot shows conditional stability instantly and graphically, as Figure 4 indicates.

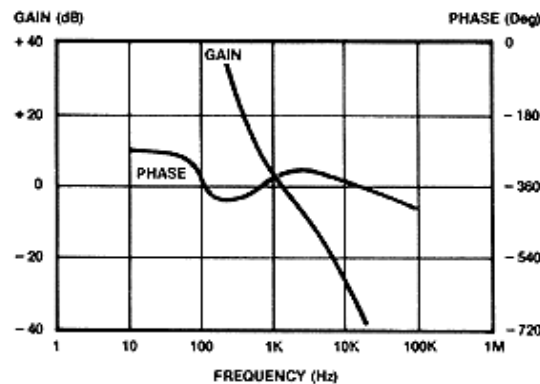

Figure 4. Conditionally Stable Loop

A second problem with step load testing is that poor performance is not necessarily associated with loop bandwidth or phase margin. Figure 5 shows the open-loop gain of a power supply with an undamped input filter. The gain crosses 0 dB and the phase shift approaches 360° at a frequency lower than true crossover frequency.

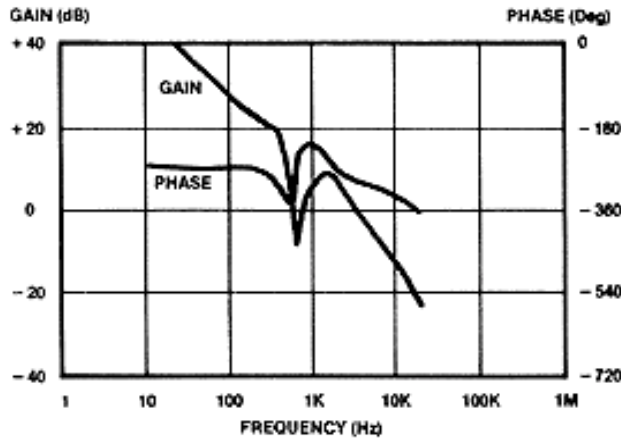

Figure 5. Loop with Undamped Input Filter

This condition happens at the resonant frequency of the input filter. When subjected to a step load, this supply will ring at the resonant frequency of the input filter, and no amount of modification to the feedback compensation will improve the situation. The only solution is to damp the input filter.

The input filter resonance phenomenon points out the third problem of step load testing, that test results give the designer no insight into what to do to fix the problem, or even what caused the problem. A Bode plot shows immediately what is wrong, and an experienced designer can use the data to adjust circuit values or damping to correct design defects in a straightforward and efficient manner.

Summary

Many stability and performance problems in the application of power supplies can be avoided by specifying gain and phase margins of the various loops. Test equipment is now available which performs this type of testing quickly and easily. This new equipment makes it feasible to test stability margins at all conditions of line, load, and temperature. In addition, margins can be tested with various external influences simulated, such as remote sensing and/or additional output filter capacitance. Bode plot testing in production quickly identifies "out-of-family" units that do not match production performance, indicating the presence of components which are wrong or damaged. By placing reasonable values for nominal or worst-case stability margins in procurement specifications, the knowledgeable buyer can avoid field failures or application problems when power supplies are mated to using equipment.

References

1. Nyquist, H., "Regeneration Theory," Bell Systems Tech J., vol II, pp. 126-147, 1932.
2. Tuttle, Wayne H., "Why Conditionally Stable Systems do not Oscillate," Proceedings of PCI '85, pp. 384-389.
3. Venable, H. Dean, "Testing Power Sources for Stability," Proceedings of the 1984 Power Sources Conference, pp. S12/1-1:14.
4. Venable, H. Dean, "Integrated Frequency Response Modeling and Measurement System with File Math," Proceedings of the 1985 Power Electronic Design Conference, pp. 195- 202.